

ACE EQUIPMENT COMPANY



C-OC

OCTAGON COMPACTOR RECEIVER CONTAINERS

PROFESSIONALLY DESIGNED FOR: INDUSTRIAL - COMMERCIAL - MUNICIPAL - RECYCLING APPLICATIONS



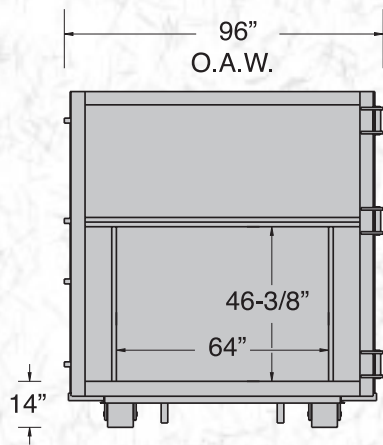

FRONT ELEVATION

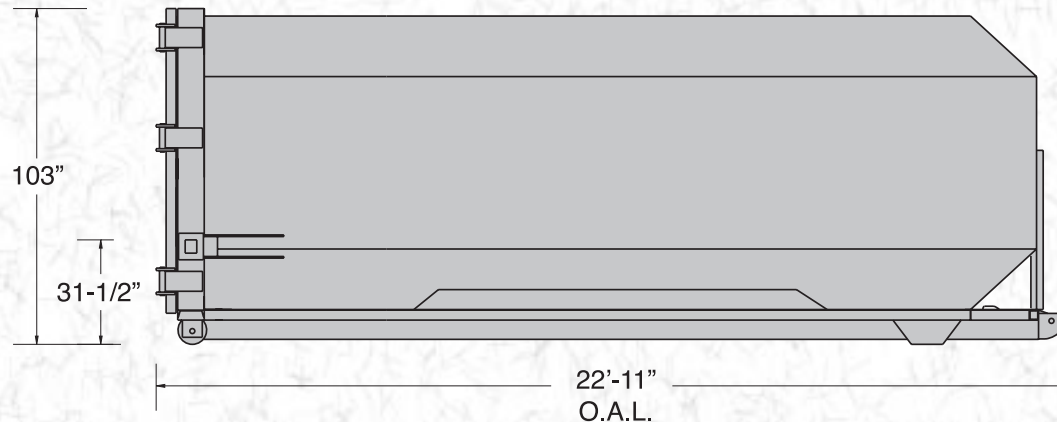

SIDE ELEVATION

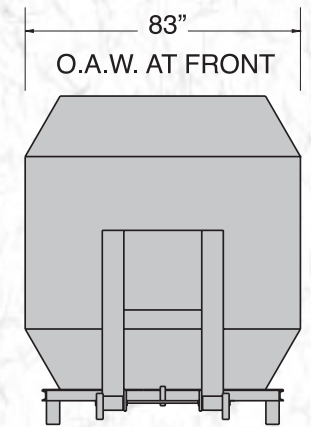

BACK ELEVATION

40 Yard Octagonal Compactor Receiver Container

Structural Specifications:

Floor	3/16" Plate
Sides	3/16" Plate
Main Rails	2" x 6" Heavy Structural Steel Tubing
Door	3/16" Plate
Hinges	3/4" Plate with 1-1/2" Diameter Pins

Optional Equipment:

- ◆ Shorter length, width and height available
- ◆ Floor 1/4" plate
- ◆ Main rails 6" x 2" x 3/8" steel tubing
- ◆ Ratchet and door seal
- ◆ 3" sump to help retain liquid
- ◆ 2" drain with gate valve
- ◆ Many others available

40 Yard Octagonal Compactor Receiver Container Shown With the A-2 Stationary Compactor and Security Chute System.



The contoured front helps the solid waste churn, along with the contoured sides no square corners for solid waste voids. This helps to create a much denser compaction of the solid waste material.



ACE Equipment Company
2843 County Road Y
Aniwa, WI 54408
(715) 449-3117